



# KEG RIVER MICROBREWERY INSTRUCTION MANUAL



**MODEL NO.: BM-S400M-1 ~ BM-S500M-1**

**Thank you for purchasing the Keg River Microbrewery system.**

**Please follow the instructions below to get the best from your machine. The processes described are just a guide, as we are aware that different brew recipes and conditions vary. The machine has been designed for you to adjust the settings to suit your own brewing requirements.**

**\* Happy Brewing \***

## Safety Instructions

- Read all the instructions carefully before use, and keep this manual for future reference.
- Do not use the device if the cord or plug is damaged. These should be replaced before use.
- Do not use an adaptor as the wattage power of this device is high.
- Use only grounded/earthed electrical socket
- Overloading the electric supply must be avoided.
- If you need to use an extension cord, do not use an extension cord under 15 amp.
- No other electrical products may be connected to this extension cord.
- Check the product's rating label and make sure the voltage is fit for your electrical outlet before using
- The device must be only used as intended. It must be operated in a safe, fault-free condition. .
- Always switch off before removing plug from the outlet.
- Unplug after use and allow cooling down before moving or cleaning.
- Place the brewer on a horizontal surface, away from table edges, hot surfaces or open fire.
- Always consider the risk of accidental leaks when choosing where to place the unit.
- Do not switch on the brewer, if it is empty of water.
- Do not allow the power cord to touch any hot surfaces of the brewer.
- To protect against electric shock, do not immerse brewer in water.
- Do not overfill the brewer, liquid will expand when heated up.
- Improper use of the brewer may result in severe scalding.
- Beware of hot steam when removing the lid.
- Avoid boil overs.
- If the brewer should boil dry there is a thermal cut-out which can automatically reset.
- However repeated overheating will eventually damage the heating element.
- Do not attempt to disassemble the brewer. This would void your warranty.
- This appliance should not be used by persons of reduced physical, sensory or mental capability, or lack of experience and knowledge

## Brewing Preparation

- The device must be positioned on a stable, secure and horizontal support structure prior to use.
- A full vessel contains boiling hot liquids and can weigh up to 40kg. 50L up to 50kgs horizontal positioning is a prerequisite for transfer pumping during the brewing process. Avoid an unsteady base.
- The device may not be moved during the brewing process. The handles are only meant for transporting the device in an empty state.
- It is imperative to keep children, frail persons, and animals away from the brewer while it is in operation. Remember boiling water is very dangerous.
- Always clean all the parts of your brewing equipment, hygiene is imperative to get good brewing results.
- Before use, it is acceptable to heat a quantity of hot water in the boiler to use for sterilizing brewing equipment

## Over Flow Pipe Assembly

- There are 2 different length pieces to the tube assembly, use the necessary length combination of pipes for the amount of grain used in the malt tube (grain basket).
- The mesh disc with 1 hole in the centre is the bottom piece. Before placing the false bottom into the malt tube, please attach the extension tubes as required, as shown in the pictures. No need to over tighten.
- After the above steps, place the false bottom and over flow pipe into malt tube.
- Screw the 2 small stainless handles to the upper disc as shown in the picture below.
- Place the white screw cap cover onto the pipe when adding the brewing ingredients.
- After adding your ingredients to the malt tube, remove the white cap and slide the upper mesh disc onto the

central pipe, and lower onto the grain, with the 2 handles facing upwards.

- You are now ready to brew. !!



## Program Setting

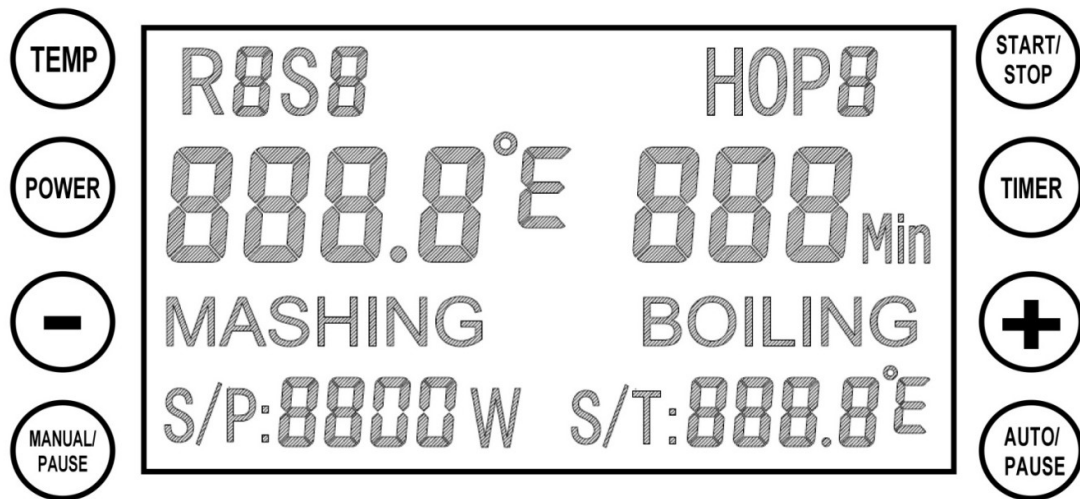

## Manual Mode Setting

1. Switch on the power switch, then press the **MANUAL** button.
2. **TEMP** is for Temperature setting, **POWER** is for Wattage setting, **TIMER** is for session timing. - All 3 of these must be set before machine will start. These can be set in any order
3. Press **START** button when all 3 settings have been made, and the manual session will start. There is "**H**" flashing at the top left corner means machine is heating.
4. The default boiling temperature is 100°C in our program, the timer will not be triggered if temperature does not indicate 100°C. In this case, please put the cover on for 1-2mins. (Or see below) to achieve 100°C on the display.
5. If the machine starts to boil, but shows a lower temp on the display, make the following adjustment to set the temp at 100°C and trigger the timer.
6. Press "**-**" and "**+**" button together until the display shows the **C1/F1** sign. Temperature correction range is from -10°C to +10°C or -50°F to +50°F
7. Press Manual/Pause button during heating, machine back to edit page. You can edit Temp/Power/Timer, then press Manual/button again to confirm and machine back to heating.
9. This function is to set the boiling temperature, Press "**-**" and "**+**" button together for 5-6s, then you can see C1 shown on the display, and press the "manual" button, you will see C2 sign. If your boiling temperature is 95°C, you can set -5°C, making the boiling temperature to be 95°C.
8. Press and hold the **TEMP button** for 5 seconds, switch degree centigrade to Fahrenheit. This operation only can be proceeded when you switch on the machine before any setting.

## Memory Function in Manual Mode

1. Press **MANUAL/PAUSE** button **in edit page** for 5seconds, and release it. You can record the last setting. There's ringing sound of bell for successful recording.
2. Press **START** button after above operation, machine back to work, and carry out the input data.
3. Press **STOP** button, machine stop working.
4. Press and hold the **AUTO/PAUSE** button in **BLANK PAGE** as below (display shown current temperature only as below) for 5 seconds to restore factory settings, there's a slower ringing for restoring successfully.

Figure 1 Example of the Blank Page

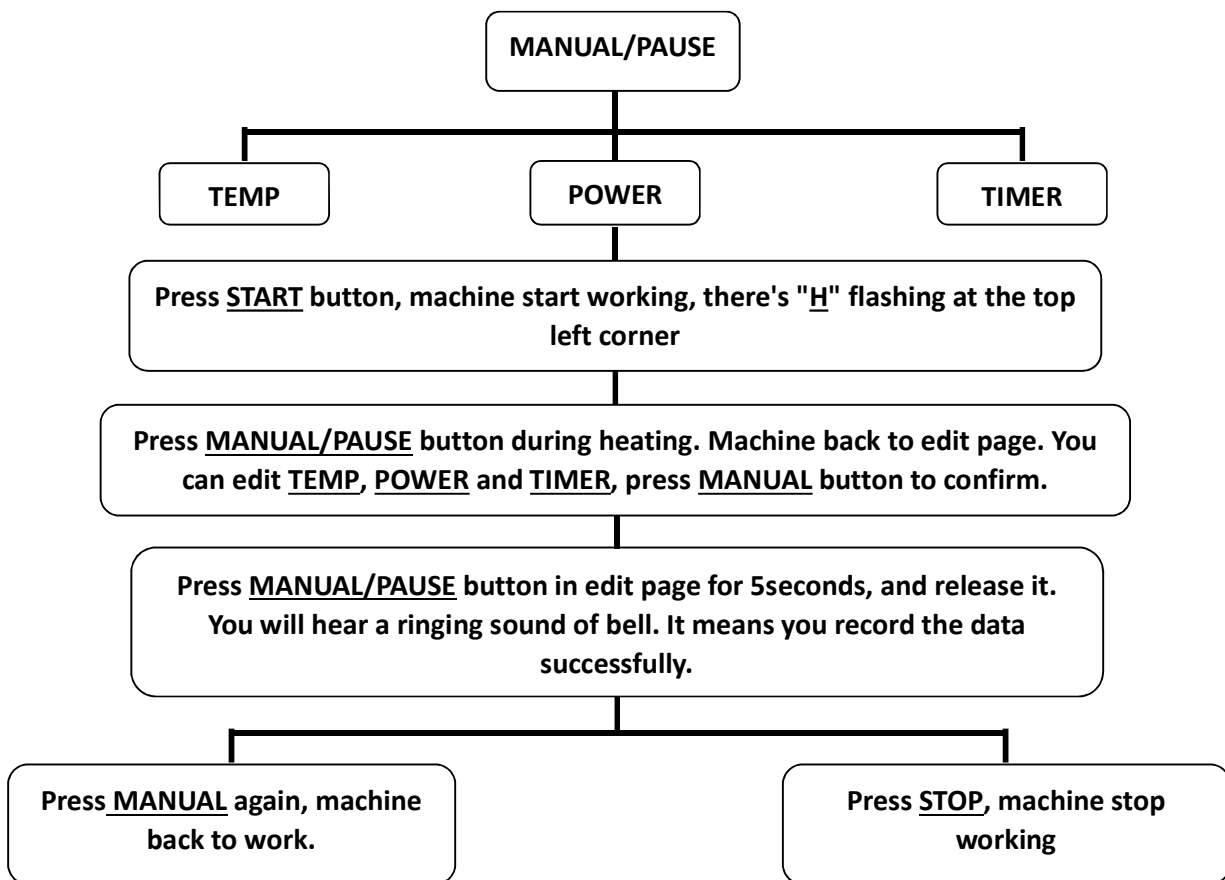

## Auto Mode Setting

1. Switch on the device, then press **AUTO** button.
2. S1 will be shown on the top left corner, input the 3 settings - **TEMP**, **TIMER** and **POWER**. (As above).
3. After you have set the 1<sup>st</sup> program, press **AUTO** button again then enter into 2<sup>nd</sup> program setting. 3<sup>rd</sup> to 9<sup>th</sup> programs are set as 1<sup>st</sup> and 2<sup>nd</sup>.
4. When you have entered up to 9 steps as you require, press the **START** button to confirm the above step mashing settings.
5. The step after boiling will be skipped if 9 steps is too much for you. This program only support one boiling setting in each Recipe. You can adjust the boiling power during operation anytime.

6. When S1 temp is reached, there is reminder ringing, timer will not countdown unless you press AUTO button to confirm. It is ingredients filling reminder.
7. The boiling reminder is same as above, when machine finish the step before boiling, there is reminder ringing, program will not enter boiling step unless you press AUTO button for confirmation. It is sparging reminder.
8. **PAUSE** button will stop the element and timer working temporarily, and you can amend the data, afterward, press **AUTO** to continue.
9. Press **START** button when auto mode is running, you can skip the step you do not need instantly.
10. **Setting hop reminder in boiling process**, press **-** or **+** for countdown timer setting. Press **TIMER** button for 2<sup>nd</sup>, 3<sup>rd</sup>...9<sup>th</sup> setting. The countdown timer must be **boiling leads time>1<sup>st</sup>>2<sup>nd</sup>>3<sup>rd</sup>...>9<sup>th</sup>**. Press **START** button start to heat.
11. Press the **POWER** and **TIMER** buttons for 5 seconds in **BLANK PAGE**, operation enter to recipe selection. Press **"-"** or **"+"** to choose required recipe. Recipe storage is up to 9 programs. Press **Start** button to confirm the selected recipe, **BLANK PAGE** will be shown on display, then press **AUTO/PAUSE** button enter the chosen recipe edit page. You can press **START** button to run the picked up program instantly or press **AUTO/PAUSE** button to edit/check the program step by step.
12. If you press **STOP** button to skip all the step, machine stop working, and display shown **END**, bell ringing for 30s, press the **STOP** button again enter to **BLANK PAGE**.

## Memory Function in Auto Mode

1. After setting all the data you need in auto mode, press **STOP** button until **BLANK PAGE**. Please do not switch off the machine! Follow below step for recording.
2. Press **MANUAL** button enter manual edit page, then press the **MANUAL** button for 5 seconds then release it. You can record the last manual and auto mode setting. There is ringing sound of bell for successful recording.
3. Switch off/on the machine, then press **AUTO** button, the 1st step of last chosen program will be shown on the display.
4. Press **START** button, machine start working.
5. Our program not support batch storage. Each recording need to repeat above instruction.

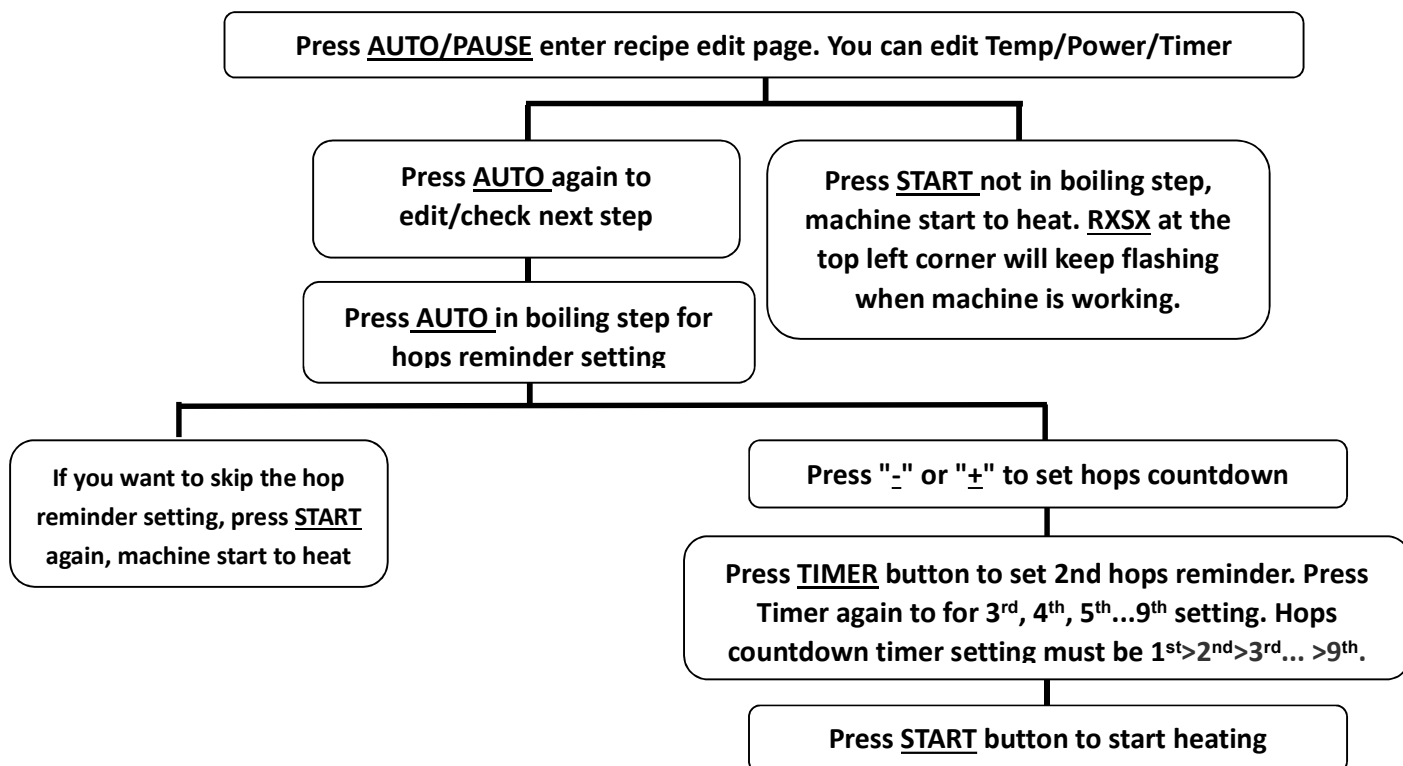

## Recipe Selection in Auto Mode

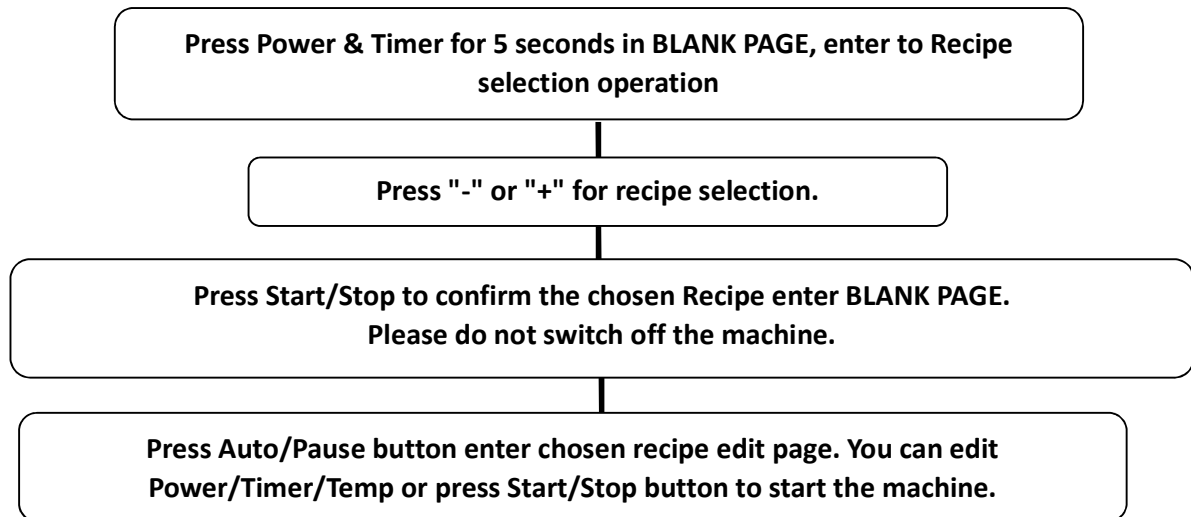

## Brewing Process (example)

- Always clean the machine before and after use.
- Assemble the Bazooka filter to the tap, and add the required quantity of water before switching on.
- Heat up the water to 66°C-68°C, then add the grain into malt tube and stir it gently.
- Start your circulation pump when the correct temperature is reached, regulate the pump flow (as shown in the section below)
- The standard heat session time is 60mins for the 1<sup>st</sup> mashing (recipes may vary)
- 2<sup>nd</sup> mashing temperature is 78-80°C, session time is 20mins (recipes may vary)
- After mashing, carefully lift up the malt tube with the separate handle, and locate the malt tube lugs onto support ring on the boiler rim.
- Use your sparging water to extract left over sugars from the grain in the malt tube. ( leave malt tube to drain into boiler for appx 10mins after sparging )
- Heat up the water to boiling temperature, (which can be done while malt tube is draining) boiling session time is 90mins.(recipes may vary)
- Add the hops etc. at correct timings according to your recipe.
- Immerse your wort chiller appx.15mins before the boil has finished, this sterilizes the equipment.
- After the boil, cool down the wort to 20°C before transferring to your fermenting vessel via the drain tap / bazooka filter on the boiler front.

## Circulation Pump

- **Running the pump without water is forbidden! Running without water will burn out the pump**
- **It is not recommended to use the pump for pumping out the wort after cooling, as there is no filter on the pump inlet. This can cause brew debris to enter the pump, potentially blocking and damaging the system.**
- Water must be in the boiler before switching on the pump.
- **Do not run the pump during wort boiling.**
- Close the (blue) valve on the circulation pipe.
- Insert the curved pipe. Press down the two handles on the connector to lock the pipe into place.
- Switch on the pump after above operation.
- Adjust the flow rate using the blue valve for correct circulation speed. (If the pump speed is too fast, the malt tube will overflow down the central pipe, and the bottom of the boiler may run dry and cause ingredients to burn and overheat the element.)

- You need to adjust the flow until a well-balanced rate of circulation is achieved.
- Switch off the pump after mashing. Please ensure not to remove the curved pipe before you close the valve and switch off the pump. (Unless you want wet feet) !!!



## Maintenance

- It is very important to clean the machine after use. The dry ingredients may stick on the metal and stick inside the pump.
- Rise the machine with 5L-10L 60c water for 15mins or more until you make sure it is clean. Turn on the pump during cleaning.
- Do not use any sharp metal implement to remove any residue. Use a soft cloth or soft scouring pad to clean the inside of the boiler. (vinegar can be good for this)
- Any wort residue marks on the boiler base should be cleaned off before next use.
- Reverse flush the pump by connecting a hose to the curved pipe.
- Suitable cleaning products can be used. (please check suitability)
- Do not splash any electronic parts of the machine.
- Do not immerse the machine in water.
- Store the machine in a dry place, do not plug in when not in use.

## Troubleshooting Tips

1	Ingredients stuck in the pump	A: Flush the pump by connecting a hose to the curve pipe B: Dismantle the pump to remove the ingredients.
2	Failing to reach 100°C	A: Put cover on for 1 to 2 mins B: Do temperature correction.
3	C1--degree centigrade temperature correction	A: Press "-" and "+" at the same time enter into C1 temperature correction setting. Setting range is from -10°C to +10°C, press TEMP button to confirm.
4	F1--Fahrenheit temperature correction	A: Press "-" and "+" at the same time enter into C1 temperature correction setting. Setting range is from -50°F to +50°F, press TEMP button to confirm
5	ERR-1 shown on display	A: Temperature is lower than -20°C, it is low temperature warning. B: Sensor connector is loosen. C: Open the underneath and check the sensor. Re-connect it if loosen.
6	ERR-2 shown on display	A: Temperature is higher than 120°C, it is overheat/boil-dry warning. B: Sensor is failure, please contact dealer for replacement.
7	Suddenly shut off during heating	A: Lower the heat up power B: Replace over heat protection thermostat

## Technical Data

<b>Model No.:</b>	BM-S400M-1	BM-S500M-1
<b>Volume:</b>	40L up to top, 30L to full line	52L up to top, 45L to full line
<b>Voltage:</b>	110V-120V	220V-240V
<b>Power:</b>	1800W	3000W
<b>Frequency:</b>	50Hz/60Hz	50Hz/60Hz

## Electric Circuit

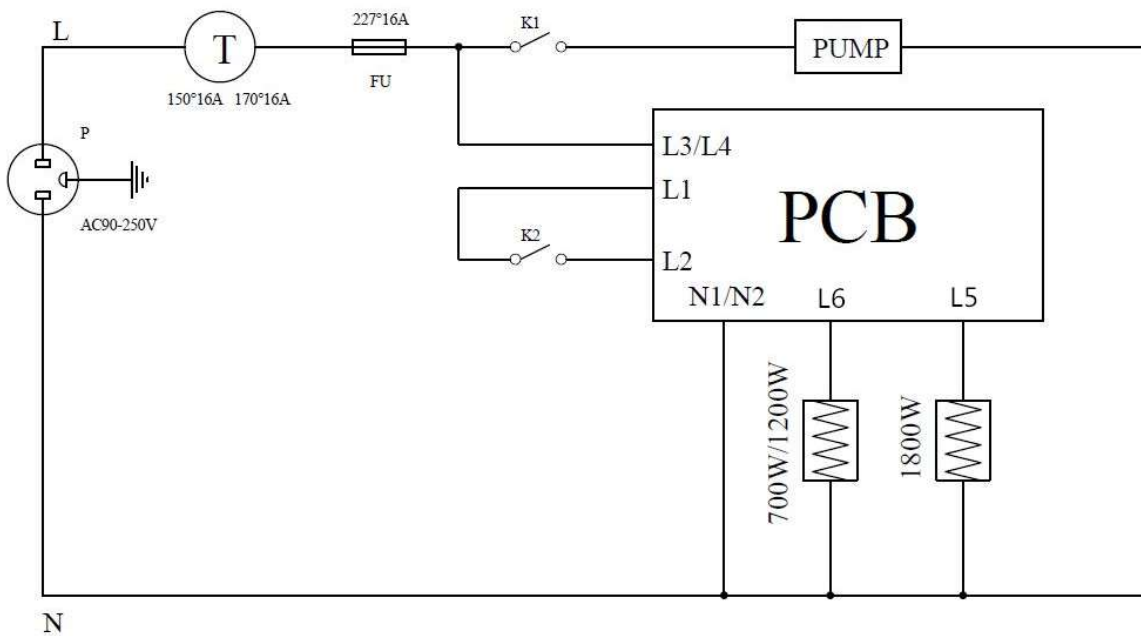

Contact Information:

Keg River Corp

Web Page: [www.kegriverbrewer.com](http://www.kegriverbrewer.com)

Email: [support@kegriverbrewer.com](mailto:support@kegriverbrewer.com)